

Approval body for construction products
and types of construction

Bautechnisches Prüfamt

An institution established by the Federal and
Laender Governments



European Technical Assessment

ETA-09/0342
of 1 March 2018

English translation prepared by DIBt - Original version in German language

General Part

Technical Assessment Body issuing the
European Technical Assessment:

Deutsches Institut für Bautechnik

Trade name of the construction product

Highload Anchor SLZ

Product family
to which the construction product belongs

Torque controlled expansion anchor made of galvanised
steel of size 14/M10 for use in concrete

Manufacturer

MKT
Metall-Kunststoff-Technik GmbH & Co. KG
Auf dem Immel 2
67685 Weilerbach
DEUTSCHLAND

Manufacturing plant

Werk 1,D

This European Technical Assessment
contains

12 pages including 3 annexes which form an integral part
of this assessment

This European Technical Assessment is
issued in accordance with Regulation (EU)
No 305/2011, on the basis of

EAD 330232-00-0601

European Technical Assessment

ETA-09/0342

English translation prepared by DIBt

Page 2 of 12 | 1 March 2018

The European Technical Assessment is issued by the Technical Assessment Body in its official language. Translations of this European Technical Assessment in other languages shall fully correspond to the original issued document and shall be identified as such.

Communication of this European Technical Assessment, including transmission by electronic means, shall be in full. However, partial reproduction may only be made with the written consent of the issuing Technical Assessment Body. Any partial reproduction shall be identified as such.

This European Technical Assessment may be withdrawn by the issuing Technical Assessment Body, in particular pursuant to information by the Commission in accordance with Article 25(3) of Regulation (EU) No 305/2011.

Specific Part

1 Technical description of the product

The Highload Anchor SLZ an anchor made of galvanized steel which is placed into a drilled hole and anchored by torque controlled expansion.
 The product description is given in Annex A.

2 Specification of the intended use in accordance with the applicable European Assessment Document

The performances given in Section 3 are only valid if the anchor is used in compliance with the specifications and conditions given in Annex B.
 The verifications and assessment methods on which this European Technical Assessment is based lead to the assumption of a working life of the anchor of at least 50 years. The indications given on the working life cannot be interpreted as a guarantee given by the producer, but are to be regarded only as a means for choosing the right products in relation to the expected economically reasonable working life of the works.

3 Performance of the product and references to the methods used for its assessment

3.1 Mechanical resistance and stability (BWR 1)

Essential characteristic	Performance
Characteristic resistance under static and quasi-static loading, displacements	See Annex C1 to C2

3.2 Safety in case of fire (BWR 2)

Essential characteristic	Performance
Reaction to fire	Class A1
Resistance to fire	See Annex C3

4 Assessment and verification of constancy of performance (AVCP) system applied, with reference to its legal base

In accordance with the European Assessment Document EAD 330232-00-0601 the applicable European legal act is: [96/582/EC].
 The system to be applied is: 1

5 Technical details necessary for the implementation of the AVCP system, as provided for in the applicable EAD

Technical details necessary for the implementation of the AVCP system are laid down in the control plan deposited with Deutsches Institut für Bautechnik.

Issued in Berlin on 1 March 2018 by Deutsches Institut für Bautechnik

BD Dipl.-Ing. Andreas Kummerow
Head of Department

beglaubigt:
Lange

Anchor type SLZ-B with threaded bolt

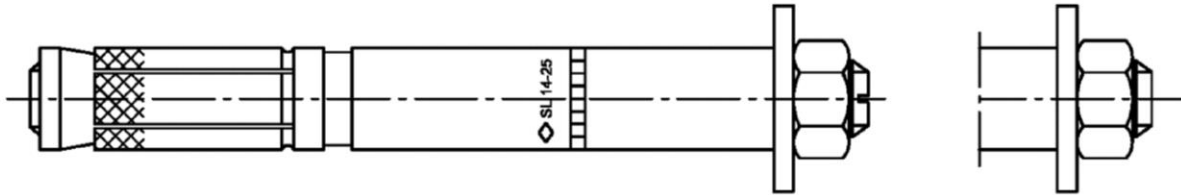

Anchor type SLZ-S with hexagon head screw

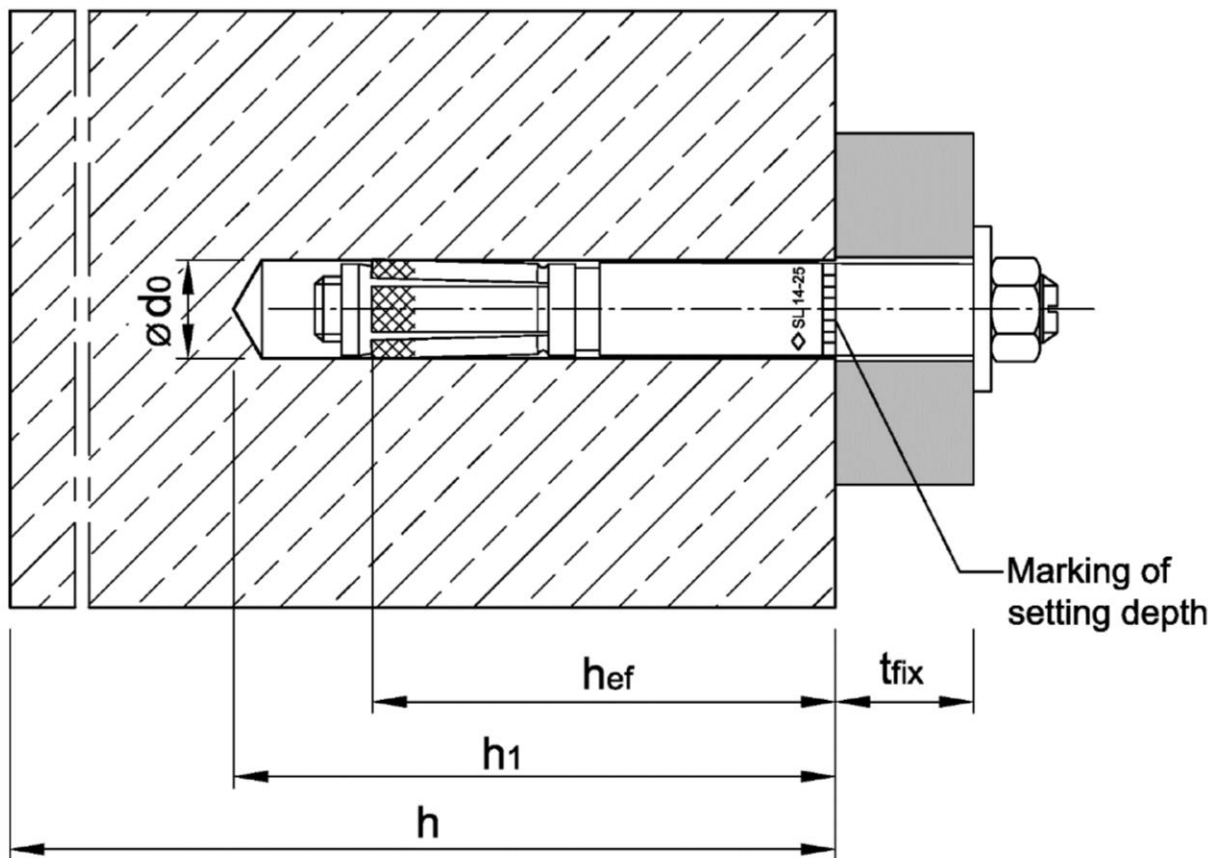
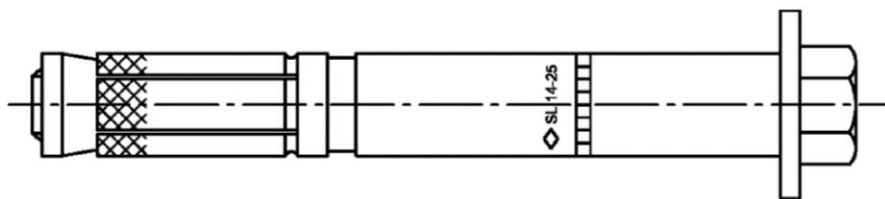

Highload Anchor SLZ

Product description
Installation situation

Annex A1

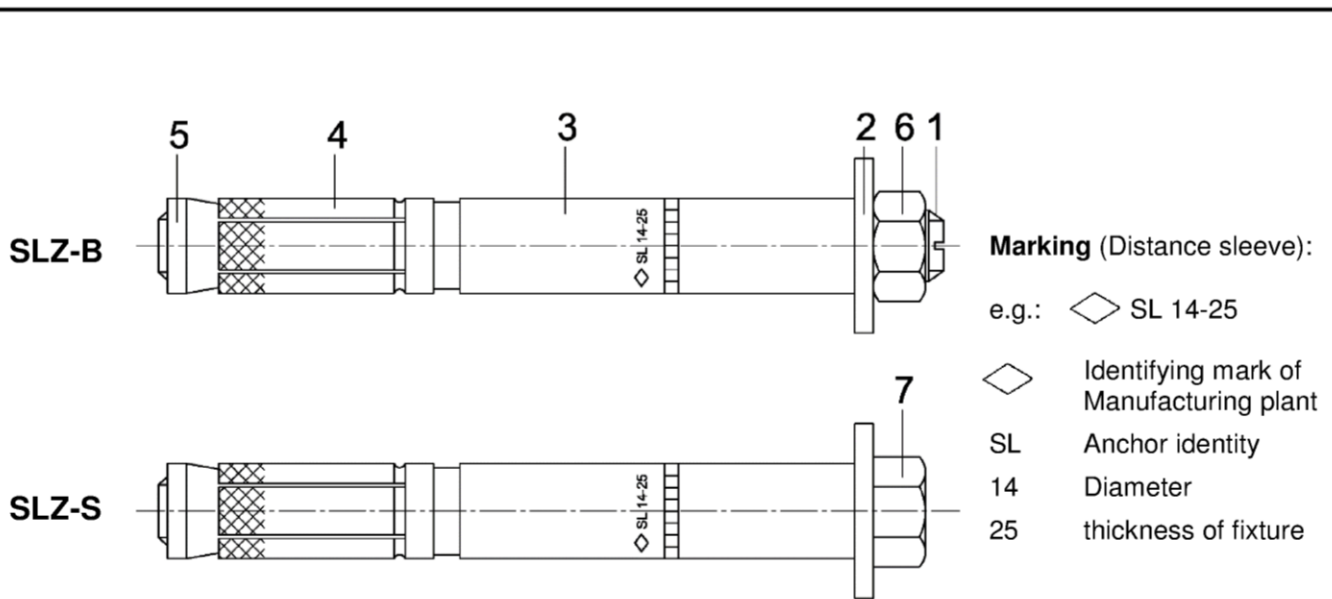

Table A1: Designation of anchor parts and materials

Part	Designation	Materials galvanised $\geq 5 \mu\text{m}$, acc. to EN ISO 4042:1999
1	Threaded bolt	Steel, Strength class 8.8, EN ISO 898-1:2013
2	Washer	Steel, EN 10139:2016
3	Distance sleeve	Steel tube EN 10305-2:2016; EN 10305-3:2016;
4	Expansion sleeve	Steel tube EN 10305-2:2016; EN 10305-3:2016;
5	Threaded cone	Steel, EN 10083-2:2006, plastic coated
6	Hexagon nut	Steel, Strength class 8, EN ISO 898-2:2012
7	Hexagon head screw	Steel, Strength class 8.8, EN ISO 898-1:2013

Highload Anchor SLZ

Product description
Anchor dimensions, marking and materials

Annex A2

Specifications of intended use

Anchorage subject to:

- Static or quasi-static action
- fire exposure

Base materials:

- Reinforced or unreinforced normal weight concrete according to EN 206-1:2000
- Strength classes C20/25 to C50/60 according to EN 206-1:2000
- Cracked and uncracked concrete

Use conditions (Environmental conditions):

- Structures subject to dry internal conditions (zinc plated steel).

Design:

- Anchorages are designed under the responsibility of an engineer experienced in anchorages and concrete work.
- Verifiable calculation notes and drawings are prepared taking account of the loads to be anchored. The position of the anchor is indicated on the design drawings (e.g. position of the anchor relative to reinforcement or to supports, etc.).
- Anchorages are designed according to FprEN 1992-4: 2016 and TR 055.

Installation:

- Anchor installation carried out by appropriately qualified personnel and under the supervision of the person responsible for technical matters of the site.
- Positioning of the drill holes without damaging the reinforcement
- In case of aborted hole: new drilling at a minimum distance away of twice the depth of the aborted hole or smaller distance if the aborted drill hole is filled with high strength mortar and if under shear or oblique tension load it is not in the direction of load application.
- Anchor installation such that the effective anchorage depth is complied with. This compliance is ensured, when the embedment mark of the anchor does no more exceed the concrete surface
- Drilling by hammer drill bit (use of vacuum drill bit is admissible)

Highload Anchor SLZ

Intended use
Specifications

Annex B1

Installation instructions

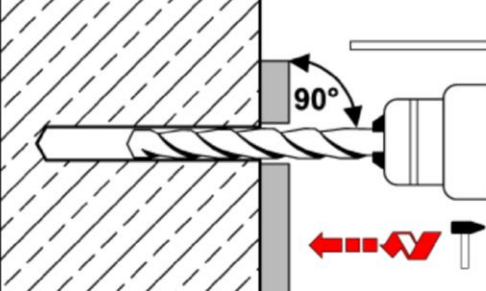
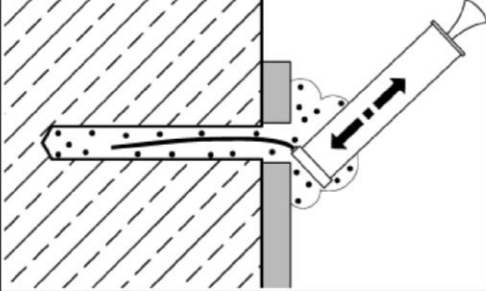
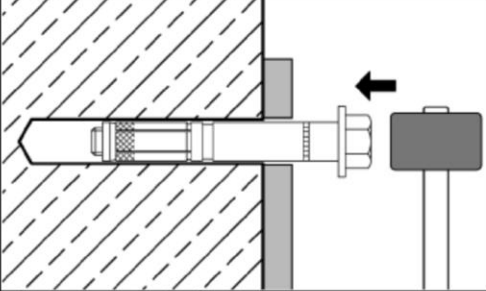
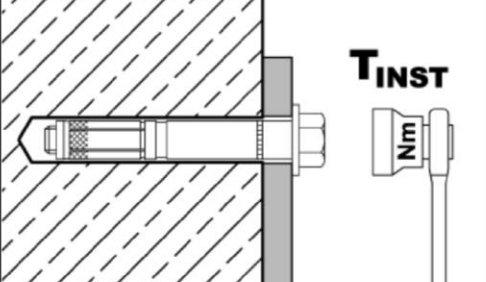
1		<p>Drill hole perpendicular to concrete surface. Using a vacuum drill bit, proceed with step 3.</p>
2		<p>Blow out dust. Alternatively vacuum clean down to the bottom of the hole.</p>
3		<p>Drive in anchor.</p>
4		<p>Apply tightening torque T_{inst} by using torque wrench.</p>

Highload Anchor SLZ

Intended use
Installation instructions

Annex B2

Table B1: Installation parameters

Anchor size			14/M10
Size of thread			M10
Effective anchorage depth	h_{ef}	[mm]	65
Nominal diameter of drill bit	d_0	[mm]	14
Cutting diameter of drill bit	$d_{cut} \leq$	[mm]	14,5
Depth of drill hole	$h_1 \geq$	[mm]	85
Diameter of clearance hole in the fixture mounted on distance sleeve	$d_f \leq$	[mm]	16
Diameter of clearance hole in the fixture mounted on threaded bolt	$d_f \leq$	[mm]	12
Installation torque	T_{inst}	[Nm]	50
Minimum thickness of member	h_{min}	[mm]	130
Minimum spacing	s_{min}	[mm]	60
	$c \geq$	[mm]	120
Minimum edge distance	c_{min}	[mm]	70
	$s \geq$	[mm]	130

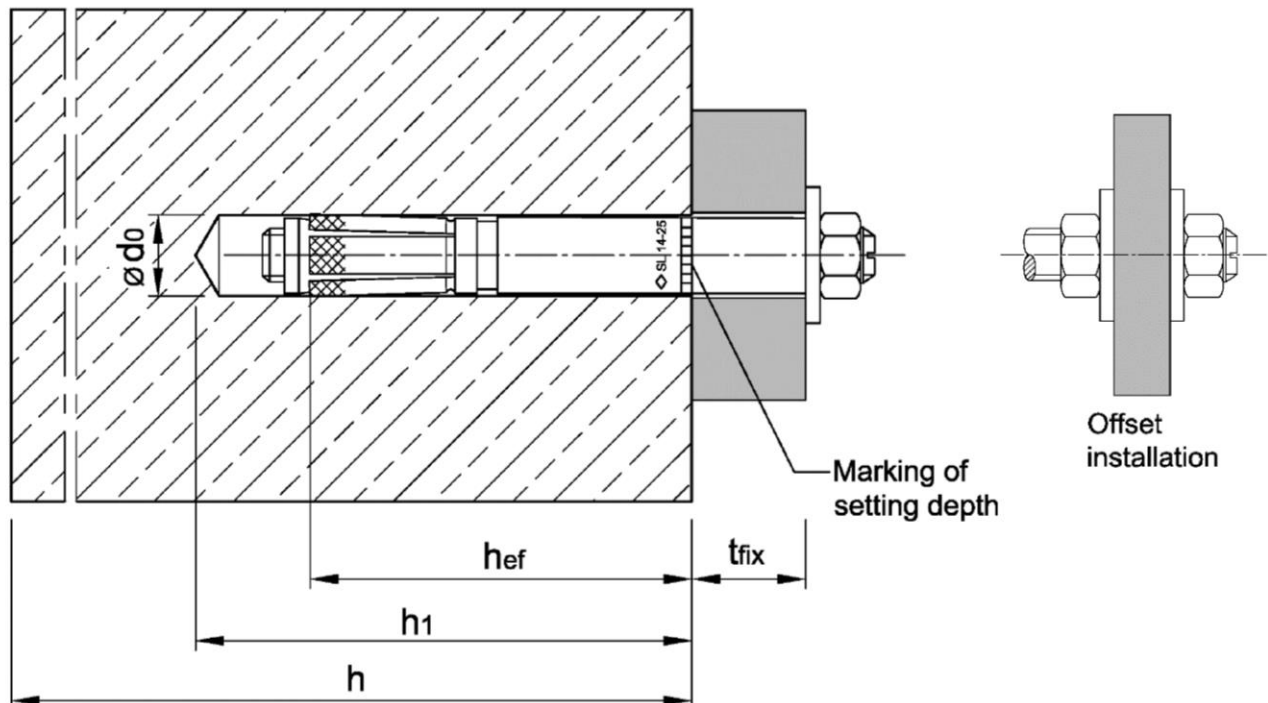

Highload Anchor SLZ

Intended use
Installation parameters

Annex B3

Table C1: Characteristic values for tension loads

Anchor size			14/M10
Installation safety factor	γ_{inst}	[-]	1,0
Steel failure			
Characteristic resistance	$N_{RK,s}$	[kN]	46
Partial safety factor	γ_{Ms}	[-]	1,5
Pull-out failure			
Characteristic resistance in cracked concrete C20/25	$N_{RK,p}$	[kN]	12
Characteristic resistance in uncracked concrete C20/25	$N_{RK,p}$	[kN]	20
Increasing factors for $N_{RK,p}$	ψ_C	[-]	$\left(\frac{f_{ck}}{20}\right)^{0,5}$
Concrete cone failure			
Effective Anchorage depth	h_{ef}	[mm]	65
Spacing	$s_{cr,N}$	[mm]	3 h_{ef}
Edge distance	$c_{cr,N}$	[mm]	1,5 h_{ef}
Factor k_1 for cracked concrete	$k_{cr,N}$	[-]	7,7
Factor k_1 for uncracked concrete	$k_{ucr,N}$	[-]	11,0
Splitting failure			
Characteristic resistance in uncracked concrete	$N^0_{RK,sp}$	[kN]	min [$N_{RK,p}; N^0_{RK,c}$]
Spacing	$s_{cr,sp}$	[mm]	390
Edge distance	$c_{cr,sp}$	[mm]	195

Table C2: Displacements under tension loads

Anchor size			14/M10
Tension load in cracked concrete	N	[kN]	5,7
Displacement	δ_{N0}	[mm]	0,8
	$\delta_{N\infty}$	[mm]	1,5
Tension load in uncracked concrete	N	[kN]	9,5
Displacement	δ_{N0}	[mm]	0,3
	$\delta_{N\infty}$	[mm]	1,2

Highload Anchor SLZ

Performance
Characteristic values and displacements under **tension load**

Annex C1

Table C3: Characteristic values for shear loads

Anchor size			14/M10
Steel failure without lever arm			
Characteristic resistance, fixture mounted on distance sleeve with $t_{\text{fix}} \leq 75$ mm	$V_{\text{RK},s}^0$	[kN]	32,8
Characteristic resistance, fixture mounted on distance sleeve with $t_{\text{fix}} > 75$ mm	$V_{\text{RK},s}^0$	[kN]	23,2
Factor	k_7	[-]	1,0
Partial safety factor	γ_{Ms}	[-]	1,25
Steel failure with lever arm			
Characteristic resistance	$M_{\text{RK},s}^0$	[Nm]	60
Partial safety factor	γ_{Ms}	[-]	1,25
Concrete pry-out failure			
Factor	k_8	[-]	2,0
Concrete edge failure			
Effective length of anchor in shear loading	l_f	[mm]	65
Outside diameter of anchor	d_{nom}	[mm]	14

Table C4: Displacements under shear loads

Anchor size			14/M10
Shear load in non-cracked concrete	V	[kN]	13,2
Displacement	δ_{V0}	[mm]	2,2
	$\delta_{V\infty}$	[mm]	3,3

Highload Anchor SLZ

Performance
Characteristic values and displacements under **shear load**

Annex C2

Table C5: Characteristic values under fire exposure in concrete C20/25 to C50/60

Anchor size			14/M10	
Tension load				
Steel failure				
Characteristic resistance	R30	$N_{Rk,s,fi}$	[kN]	0,9
	R60			0,8
	R90			0,6
	R120			0,5
Shear load				
Steel failure without lever arm				
Characteristic resistance	R30	$V_{Rk,s,fi}$	[kN]	0,9
	R60			0,8
	R90			0,6
	R120			0,5
Steel failure with lever arm				
Characteristic resistance	R30	$M^0_{Rk,s,fi}$	[Nm]	1,1
	R60			1,0
	R90			0,7
	R120			0,6

Highload Anchor SLZ

Performance
Characteristic values under **fire exposure**

Annex C3